

Model D4153 3 HP 220V Magnetic Switch Instruction Sheet



Phone #: (360) 734-3482 • Online Tech Support: tech-support@shopfox.biz • Web: www.shopfox.biz



Figure 1. Model D4153 magnetic switch.

⚠ WARNING
Electrocution or fire could occur if this switch is not installed or adjusted by a qualified electrician!

←→ Contactor TECO CU-16 (220V Coil)

COLOR KEY	
BLACK	
GREEN	
RED	
YELLOW	

←→ Thermal Overload Relay TECO RHN-10K (17-24A)

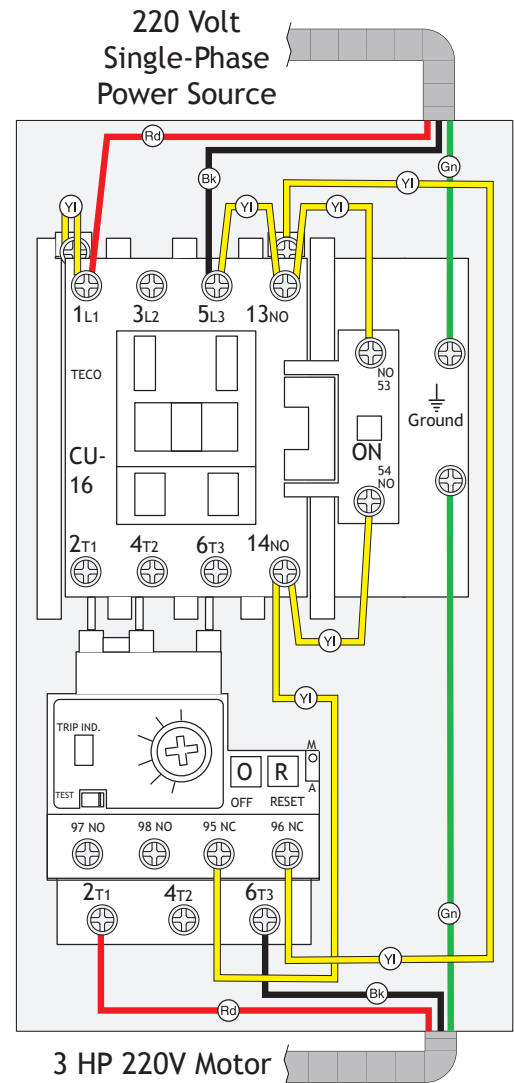

IMPORTANT: This magnetic switch toggles a motor **ON** and **OFF**, and helps provide thermal overload protection for the motor if the operating temperature gradually increases due to heavy work loads. The thermal overload relay inside is not designed to cut power in the event of a sudden motor overload or stall. To help protect a motor from this type of overload, the power supply circuit must be properly sized for the full-load current rating of the motor.

OPERATION: When pushed, the green ON button on the outside cover of the magnetic switch allows current to flow to the magnetic coil, which pulls the contactor closed. The main current then passes through the thermal overload relay to the motor. If the motor begins to overheat, the relay breaks the magnetic field, which opens the contactor and cuts current to the motor. The red OFF button manually breaks the magnetic field, which opens the contactor and disconnects the current to the motor.

Thermal Relay Overload Amp Adjustment Dial: Turn this dial to the amperage setting specified by the motor manufacturer. Typically, this setting is 100-110% of the amperage load listed on the motor data plate. Please note that turning this dial has no effect on increasing motor horsepower. If turned too high, the motor can overheat and be damaged before the relay trips.

Trip Indicator: If this window turns yellow, the thermal relay has tripped.

Manual Trip Test Lever: If the thermal relay function is in question, run the motor and use a wooden toothpick to slide the yellow test lever to the left. If the motor shuts off, the thermal relay has tripped and is functional.

Manual Contactor Override Lug: When pushed, the contactor is manually closed for troubleshooting purposes only.

ON Button: When pushed, power is sent to the magnetic field coil, closing the contactor and sending power to the motor.

Manual/Auto Reset Lever: In the up position, the thermal relay is in manual reset mode. This means you must re-install the outside cover and push the red OFF button, then push the green ON button to reset the thermal relay. In the down position, the thermal relay will automatically reset when it has cooled.

Reset Button: When pushed, the thermal relay is reset, clearing the yellow trip indicator window.

OFF Button: When pushed, the current going to the magnetic field coil is cut, which opens the contactor and cuts power to the motor.

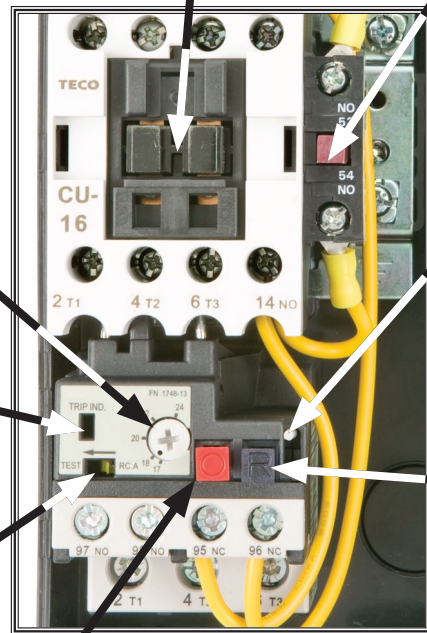

Parts Breakdown

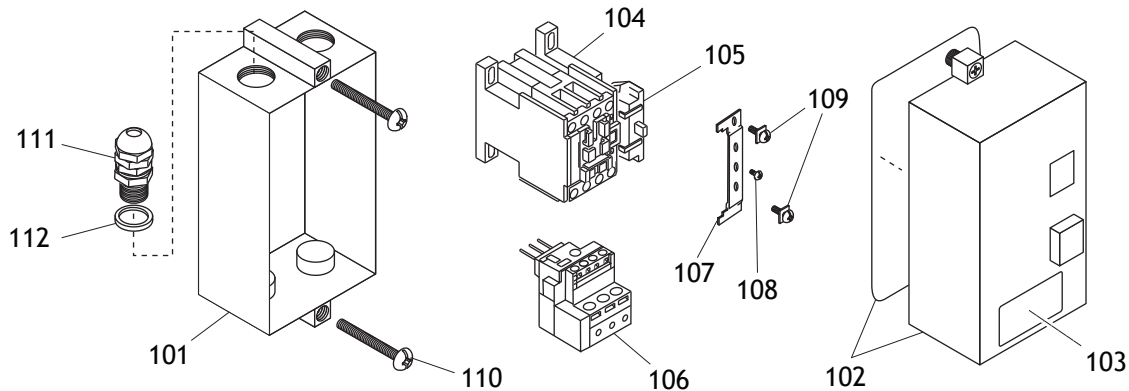

REF	PART #	DESCRIPTION
101	XD4115101	SWITCH BOX
102	XD4115102	SWITCH BOX COVER ASSEMBLY
103	XD4153103	DATA LABEL HUFB-16KK
104	XD4118104	CONTACTOR TECO CU-16 220V
105	XD4115105	FIELD SWITCH TECO CNA-1
106	XD4153106	OL RELAY TECO RHN-10K 17-24A

REF	PART #	DESCRIPTION
107	XD4115107	CONTACTOR RETAINER
108	XPS106M	PHLP HD SCR M3-.5 X 10
109	XD4115109	CAPTURED GROUND SCR M4-.7 X 10
110	XPS10	PHLP HD SCR 10-24 X 1-1/2
111	XD4115111	LIQUID-TIGHT STRAIN RELIEF PG-16
112	XD4115112	RUBBER SEAL

COPYRIGHT © JUNE, 2010 BY WOODSTOCK INTERNATIONAL, INC.

WARNING: NO PORTION OF THIS MANUAL MAY BE REPRODUCED IN ANY SHAPE OR FORM WITHOUT

#12948TS

THE WRITTEN APPROVAL OF WOODSTOCK INTERNATIONAL, INC.

Printed in Taiwan