



MODEL D3994 ACCU-SHARP® MOUNTING ATTACHMENT INSTRUCTIONS

Introduction

The Model D3994 Mounting Attachment enables the Model D3978 Accu-Sharp Jig to be mounted on a grinder 1/2" tool rest bar, as shown in **Figure 1**.

Inventory

Bag Contents (Figure 2)	Qty
A. Mounting Attachment	1
B. Cap Screws M5-.8 x 12	5
C. Hex Wrench 4mm	1

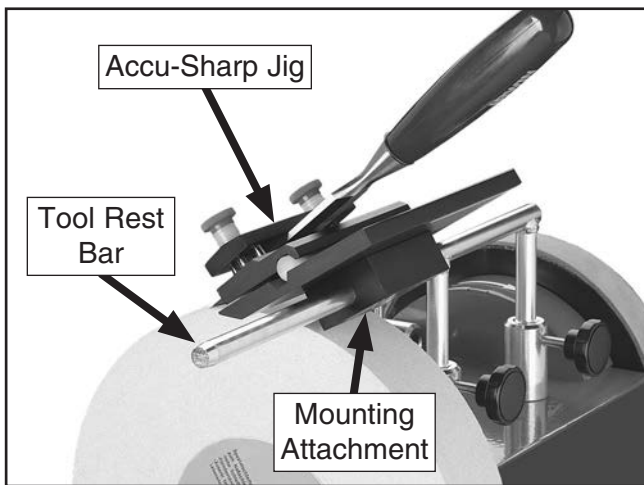

Figure 1. Model D3994 Mounting Attachment attached to Model D3978 Accu-Sharp Jig.

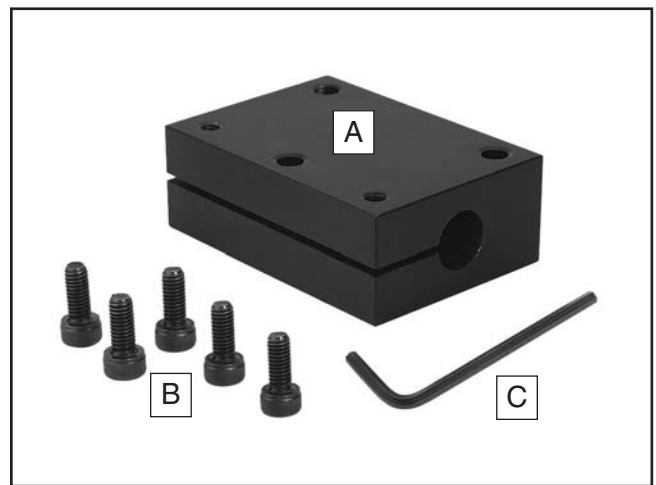

Figure 2. Shipping inventory.

!WARNING

- Read and understand your grinder owner's manual and the D3978 instructions, and follow all of the included safety precautions and instructions.
- Make sure the mounting attachment is firmly secured to the auxiliary table of the D3978 jig and to the grinder tool rest bar before beginning operation.

COPYRIGHT © OCTOBER, 2012 BY WOODSTOCK INTERNATIONAL, INC.

WARNING: NO PORTION OF THIS MANUAL MAY BE REPRODUCED IN ANY SHAPE OR FORM WITHOUT THE WRITTEN APPROVAL OF WOODSTOCK INTERNATIONAL, INC.

Assembly

1. Lay the auxiliary table of the Model D3978 Accu-Sharp Jig upside down on a stable surface (see **Figure 3**).

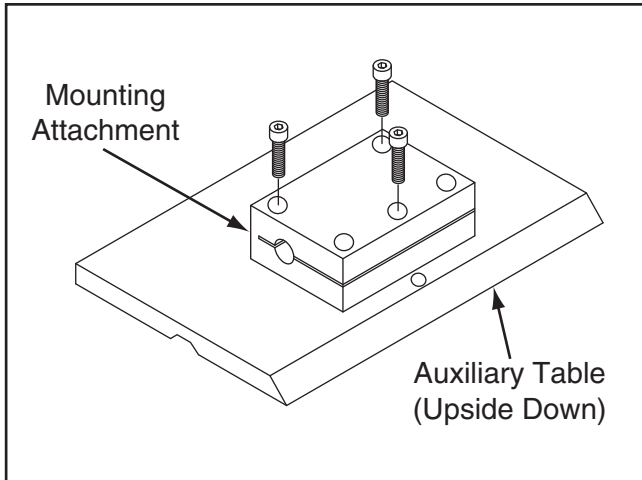

Figure 3. Installing mounting attachment to auxiliary table.

2. Position the mounting attachment on the auxiliary table, as illustrated in **Figure 3**, then secure it in place with (3) of the provided cap screws.

Mounting

1. Slide the grinder tool bar rest into the side hole of the mounting attachment, as illustrated in **Figure 4**.

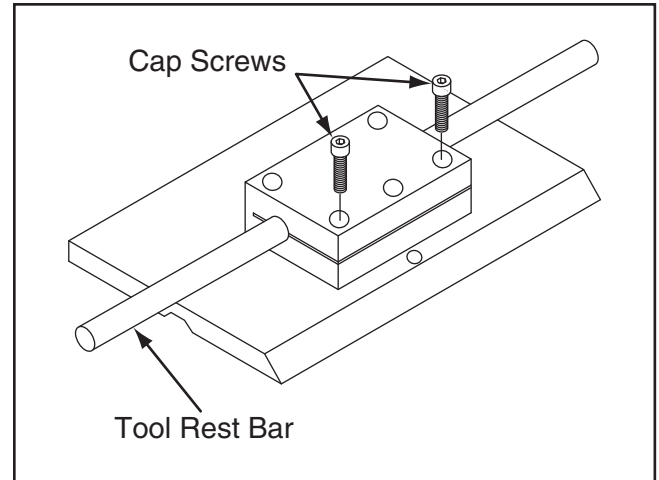

Figure 4. Securing the mounting attachment to grinder tool rest bar.

2. Loosely thread the (2) remaining cap screws into the mounting attachment (see **Figure 4**).
3. Rotate the assembly around the tool rest bar so that the auxiliary table is facing up.
4. Properly position it on the grinder for your operation, then fully tighten the cap screws used in **Step 2** to hold the assembly in place.
5. Follow the Model D3978 instructions for using the jig with your grinder.