



# MODEL D3978 ACCU-SHARP® GRINDING JIG INSTRUCTIONS

## ⚠ WARNING

To reduce the risk of serious injury when using this grinding jig, take the following precautions:

1. **GRINDER OWNER'S MANUAL.** Read and understand the owner's manual for your grinder and always follow all of the safety precautions and instructions for your grinder.
2. **EYE/FACE PROTECTION.** Always wear safety glasses or a face shield to protect yourself from flying material.
3. **HAND PLACEMENT.** Always keep your hands and fingers away from the spinning grinding wheel, and protect yourself from the sharp edges of the tool.
4. **SECURE CLAMPING.** Make sure the tool is securely clamped in the jig and that the table is firmly locked in the proper position.

## Introduction

The Model D3978 Accu-Sharp® Grinding Jig works with the tool rest table of your grinder to properly position chisels and plane irons up to 2¾" wide, as shown in **Figure 1**. The tool clamping jig uses a special plastic rod and pads to slide the tool from side-to-side across the auxiliary table and the grinding wheel.

*If you need help with your new grinding jig, call Woodstock Tech Support at: (360) 734-3482.*

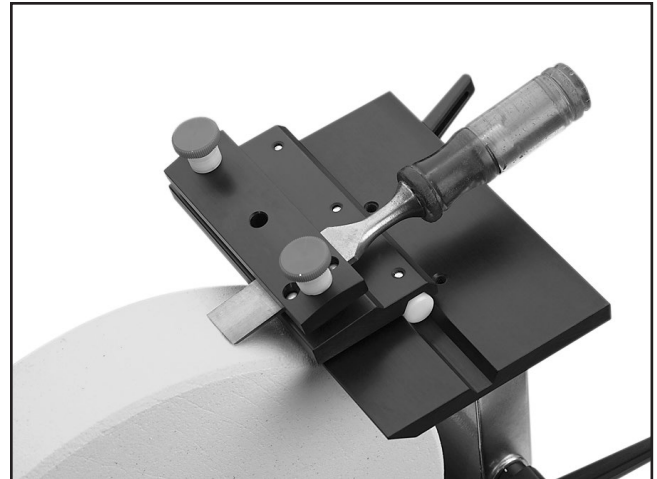

**Figure 1.** Using the Accu-Sharp Jig to grind the bevel of a flat chisel.

## Inventory

After removing the contents of the shipping package, lay them out and refer to **Figure 2** to inventory the components.

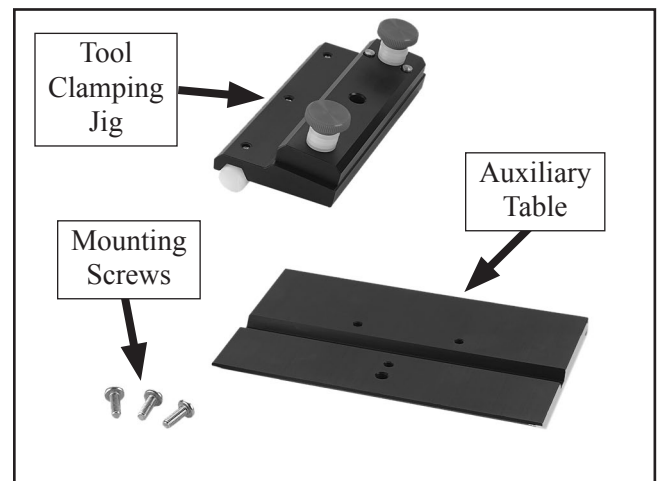

**Figure 2.** Model D3978 inventory.

**COPYRIGHT © NOVEMBER, 2008 BY WOODSTOCK INTERNATIONAL, INC. REVISED APRIL, 2014 (ST)**

**WARNING: NO PORTION OF THIS MANUAL MAY BE REPRODUCED IN ANY SHAPE OR FORM WITHOUT**

#11386TS

**THE WRITTEN APPROVAL OF WOODSTOCK INTERNATIONAL, INC.**

**Printed in China**

## Installing Auxiliary Table

1. DISCONNECT GRINDER FROM POWER!
2. Remove the tool rest table from your grinder.
3. Center the jig auxiliary table over the grinder table, then use a scratch awl through the three mounting holes of the auxiliary table to mark the grinder table (see **Figure 3**).

**Note:** Make sure that you position the tables so that when the jig is mounted on the grinder, the auxiliary table edge shown in **Figure 3** is facing the grinding wheel.

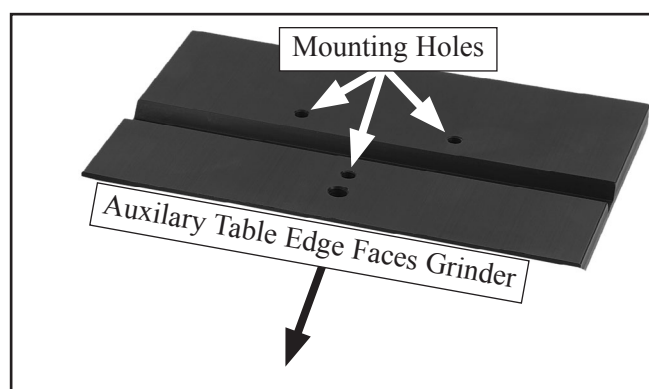
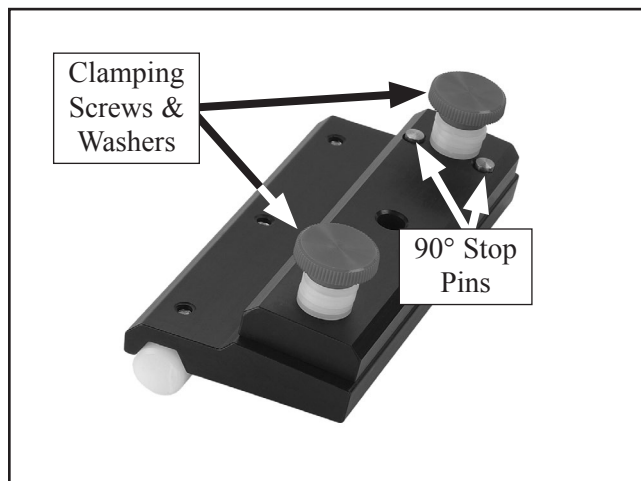

**Figure 3.** The mounting holes of the jig auxiliary table.

4. Use a center punch to indent these marks on the grinder table, then drill  $\frac{7}{32}$ " holes completely through the table.
5. Insert the three included mounting screws from underneath the grinder table, then loosely thread them into the auxiliary table.
6. Square the auxiliary table with the grinding wheel surface, then fully tighten the mounting screws.

## Operation

Loosen the clamping screws shown in **Figure 4**, slide the tool under the top bar and align its left side up against the 90° stop pins to make it square with the grinding wheel, then re-tighten the screws.

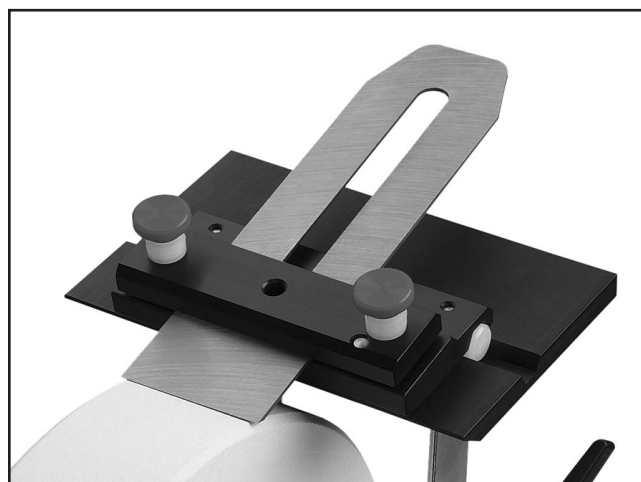

**Figure 4.** Clamping screws, washers, and stop pins.

The plastic washers of the clamping screws can be arranged to accommodate various tool thicknesses and to provide good thread bearing for the screws. However, be sure the bottom of the screws do not protrude beyond the bottom of the jig more than  $\frac{1}{8}$ " to avoid scratching the auxiliary table.

If your tool width is  $1\frac{1}{8}$ " or less, remove the right-hand clamping screw and washers and thread it into the middle hole to provide secure clamping.

Place the tool and jig on the auxiliary table, align and lock the table in place, then slide the tool across the rotating grinding wheel with light pressure (see **Figure 5**).



**Figure 5.** Plane iron clamped in the jig.