

# Model D2254-6, D2303 Wood Vises Instruction Sheet



Phone #: (360) 734-3482 • Online Tech Support: tech-support@shopfox.biz • Web: www.shopfox.biz

## Introduction

Your new Wood Vise (Figure 1) is designed to fit on workbenches 2<sup>1</sup>/<sub>4</sub>" and thicker, but can be adapted to workbenches down to 1<sup>1</sup>/<sub>2</sub>" thick by using a shim. Holes are pre-drilled in the jaw faces to attach aftermarket or shop-built wood clamping vise jaw pads.

## Specifications

Model	D2254	D2255	D2256	D2303
Jaw Width	6"	8"	6 <sup>1</sup> / <sub>2</sub> "	10"
Workbench Thickness	2 <sup>1</sup> / <sub>4</sub> "	2 <sup>1</sup> / <sub>4</sub> "	2 <sup>1</sup> / <sub>4</sub> "	2 <sup>1</sup> / <sub>4</sub> "
Maximum Jaw Opening	5 <sup>5</sup> / <sub>8</sub> "	7 <sup>1</sup> / <sub>4</sub> "	7 <sup>3</sup> / <sub>8</sub> "	8 <sup>3</sup> / <sub>8</sub> "
Weight	7 lbs.	11 lbs.	8 lbs.	14 lbs.

## Installation

1. Have another person hold the vise up against the workbench in the desired mounting location.

**Model D2256 Only:** If the workbench has holes for bench dogs, make sure the bench dog on the vise is aligned with those holes.

**Note:** If the workbench is less than 2<sup>1</sup>/<sub>4</sub>" thick, use a piece of scrap wood (Figure 2) between the vise and workbench as a shim. Cut the shim to the necessary thickness so the vise does not protrude above the workbench after mounting.

2. Use a pencil to mark the workbench through the four vise mounting holes (Figure 3) so you know where to drill pilot holes in the workbench.
3. Use a 1/8" drill bit to drill pilot holes approximately 1<sup>1</sup>/<sub>2</sub>" deep in the underside of the workbench.

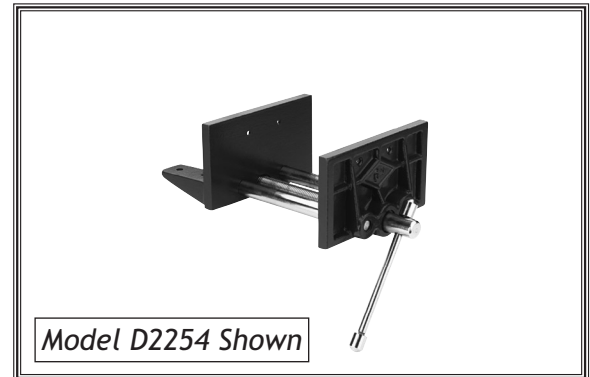


Figure 1. Shop Fox wood vise.

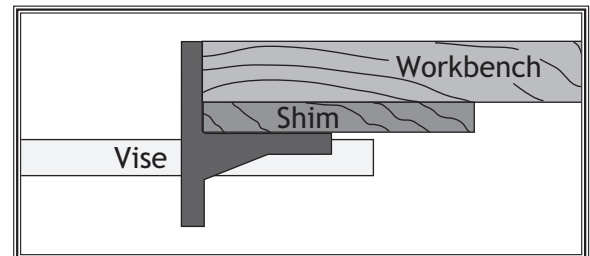


Figure 2. Shim placed between workbench and vise for workbenches under 2<sup>1</sup>/<sub>4</sub>".

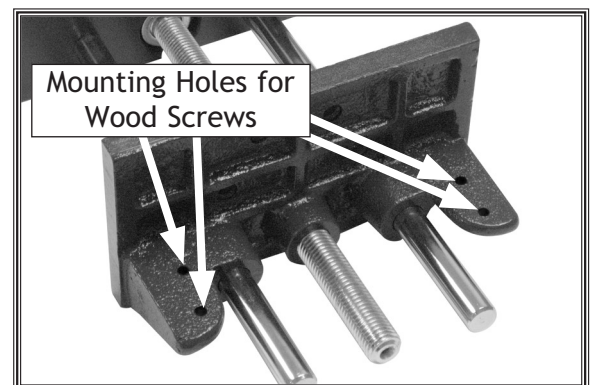


Figure 3. Mounting hole locations.

**COPYRIGHT © FEBRUARY, 2008 BY WOODSTOCK INTERNATIONAL, INC.**

**WARNING: NO PORTION OF THIS MANUAL MAY BE REPRODUCED IN ANY SHAPE OR FORM WITHOUT**

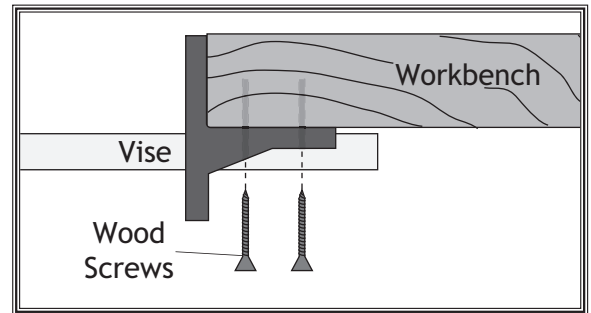
#10497TR

**THE WRITTEN APPROVAL OF WOODSTOCK INTERNATIONAL, INC.**

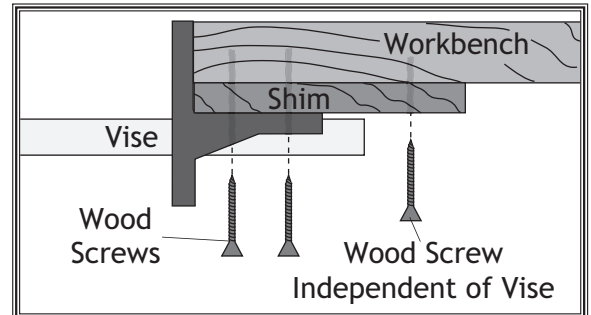
**Printed in China**

- Attach the vise to the workbench with four #10 x 2" wood screws through the underside of the workbench, as shown in **Figure 4**.

**Note:** *If you're using a shim, make sure the wood screws pass completely through the shim and secure at least halfway into the workbench thickness, as shown in **Figure 5**. You may need wood screws of a different length than given in **Step 4** when using a shim. Also, for added holding strength, attach the shim directly to the workbench with wood screws that are independent of the vise.*



**Figure 4.** Attaching vise to workbench.



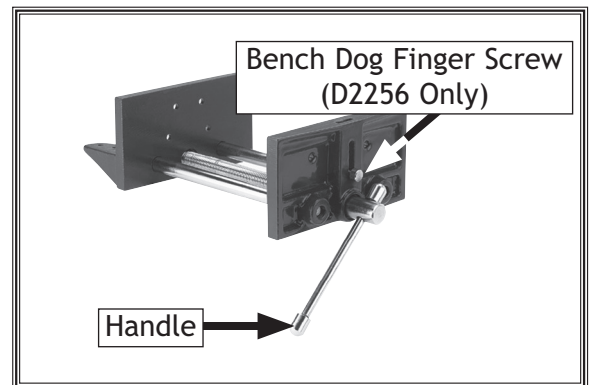
**Figure 5.** Attaching vise to workbench with shim between vise and workbench.

## Operation

Rotating the vise handle (**Figure 6**) clockwise moves the movable jaw toward the fixed jaw.

Rotating the vise handle counterclockwise moves the movable jaw away from the fixed jaw.

**D2256 Only:** Tighten/loosen the bench dog finger screw (**Figure 6**) to adjust the height of the bench dog.



**Figure 6.** Operation controls of vise.

## Accessories

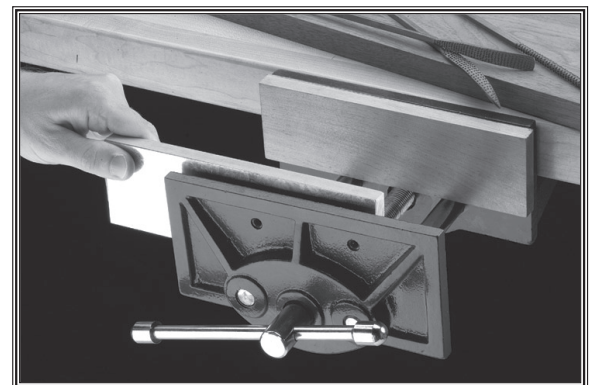
Ask your Shop Fox dealer for the wood-faced magnetic jaw pads shown in **Figure 7**.

## Maintenance

The painted parts of the vise can be cleaned with a damp rag. If wood pitch has built up on the components, clean this with a pitch dissolver or blade and bit cleaner.

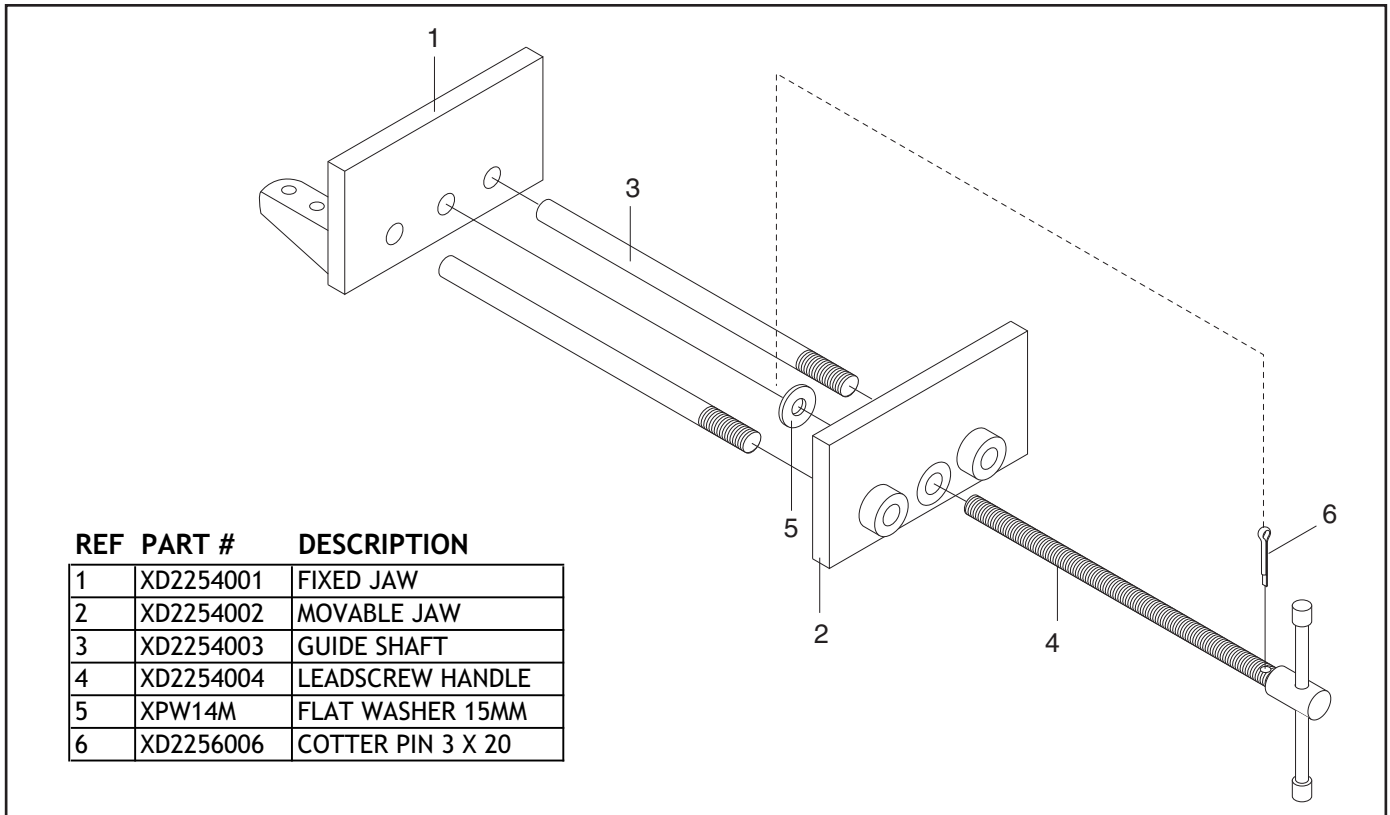
Lubricate the leadscrew with a dry lubrication, such as silicone or graphite, that will not cause sawdust to stick to the threads.

If material becomes built up on the threads, clean thoroughly with a pitch dissolver.

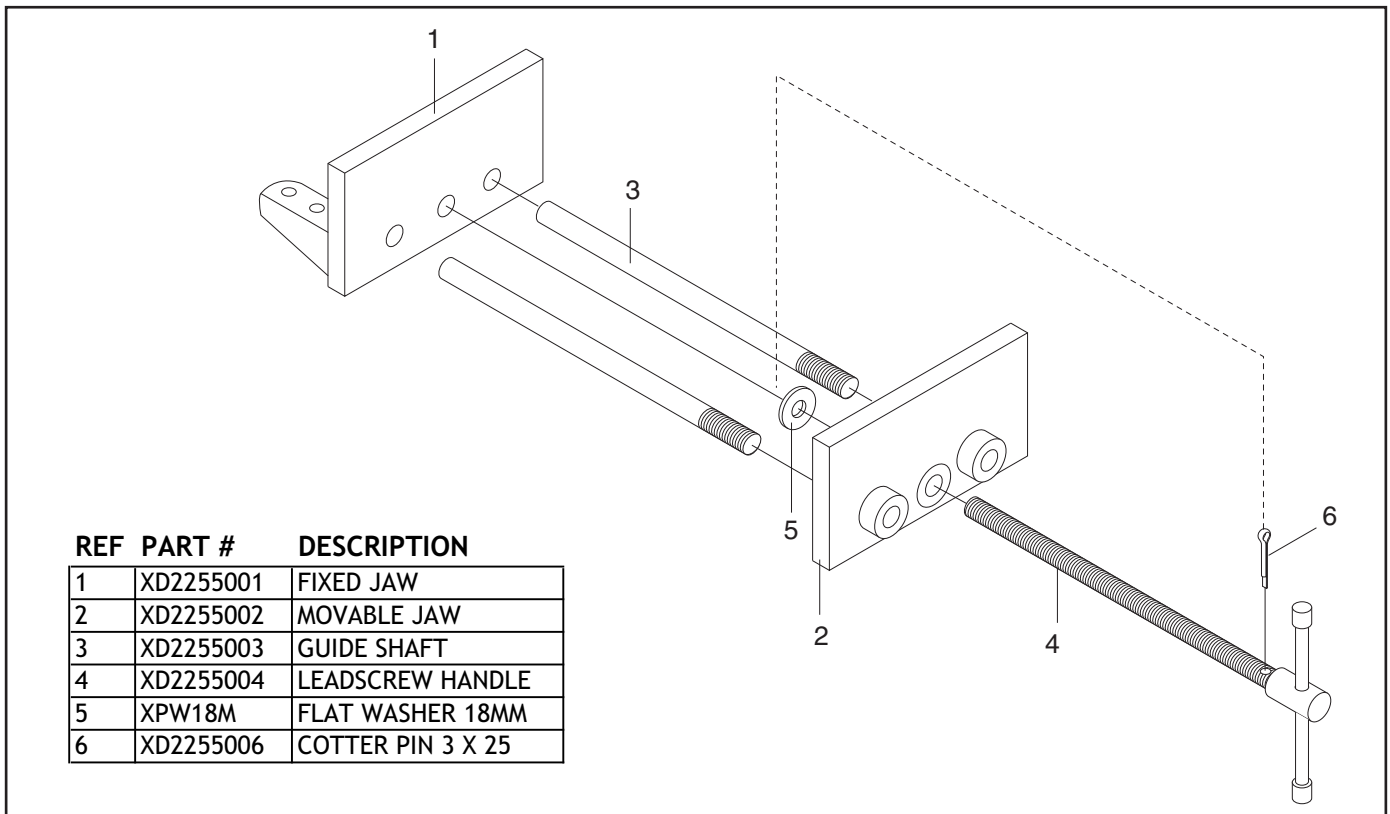


**Figure 7.** Shop Fox wood-faced magnetic jaw pads (Models D3127-D3133).

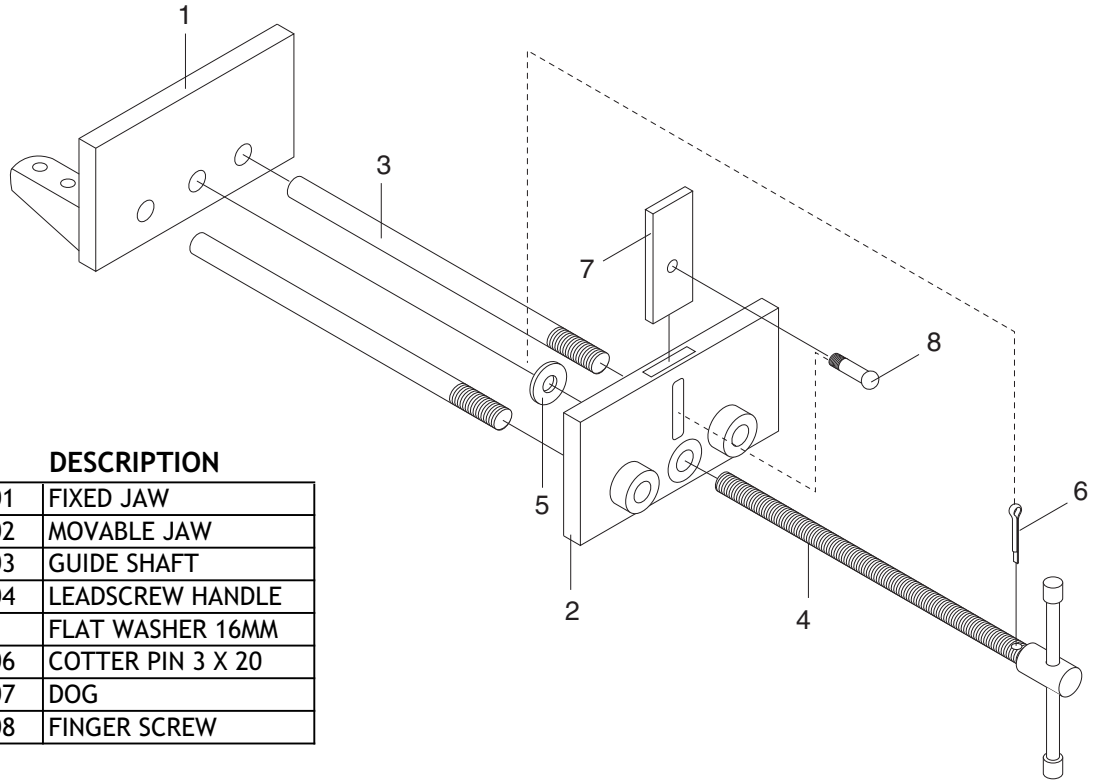
## D2254 Parts



## D2255 Parts

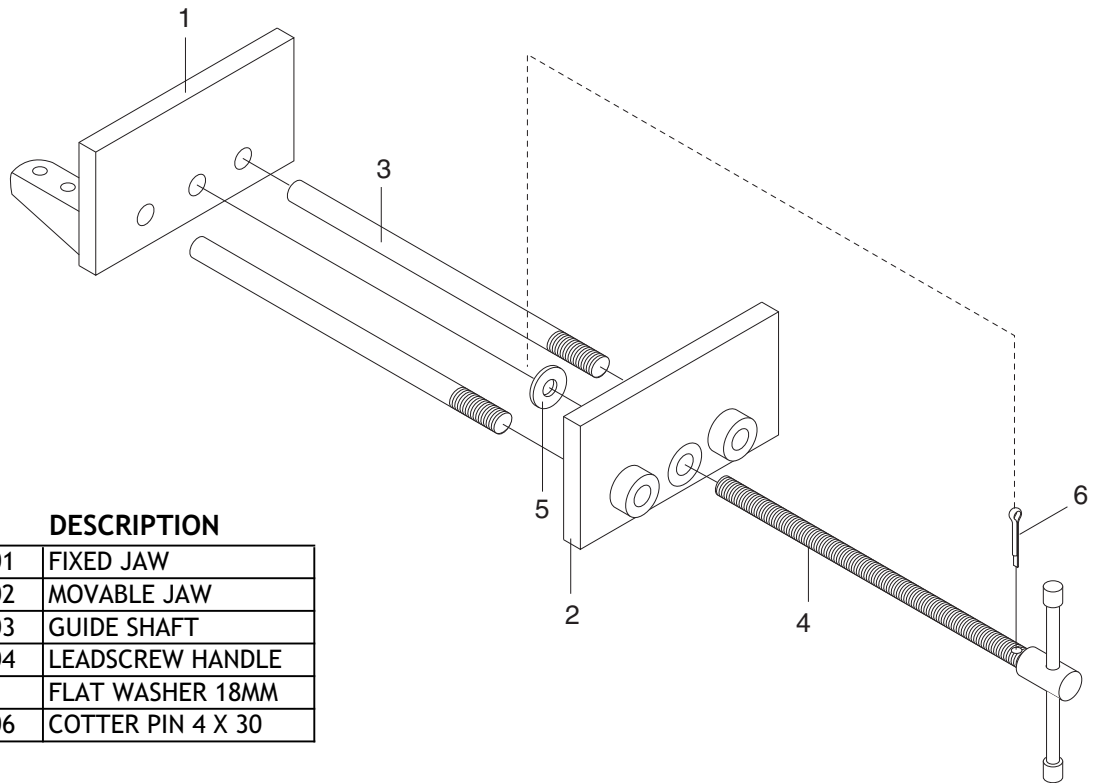


## D2256 Parts



REF	PART #	DESCRIPTION
1	XD2256001	FIXED JAW
2	XD2256002	MOVABLE JAW
3	XD2256003	GUIDE SHAFT
4	XD2256004	LEADSCREW HANDLE
5	XPW08M	FLAT WASHER 16MM
6	XD2256006	COTTER PIN 3 X 20
7	XD2256007	DOG
8	XD2256008	FINGER SCREW

## D2303 Parts



REF	PART #	DESCRIPTION
1	XD2303001	FIXED JAW
2	XD2303002	MOVABLE JAW
3	XD2303003	GUIDE SHAFT
4	XD2303004	LEADSCREW HANDLE
5	XPW18M	FLAT WASHER 18MM
6	XD2303006	COTTER PIN 4 X 30